

Catalog No. H-102NV  
Jun. 2019

# Union Bonnet Needle Valves

## GB Series

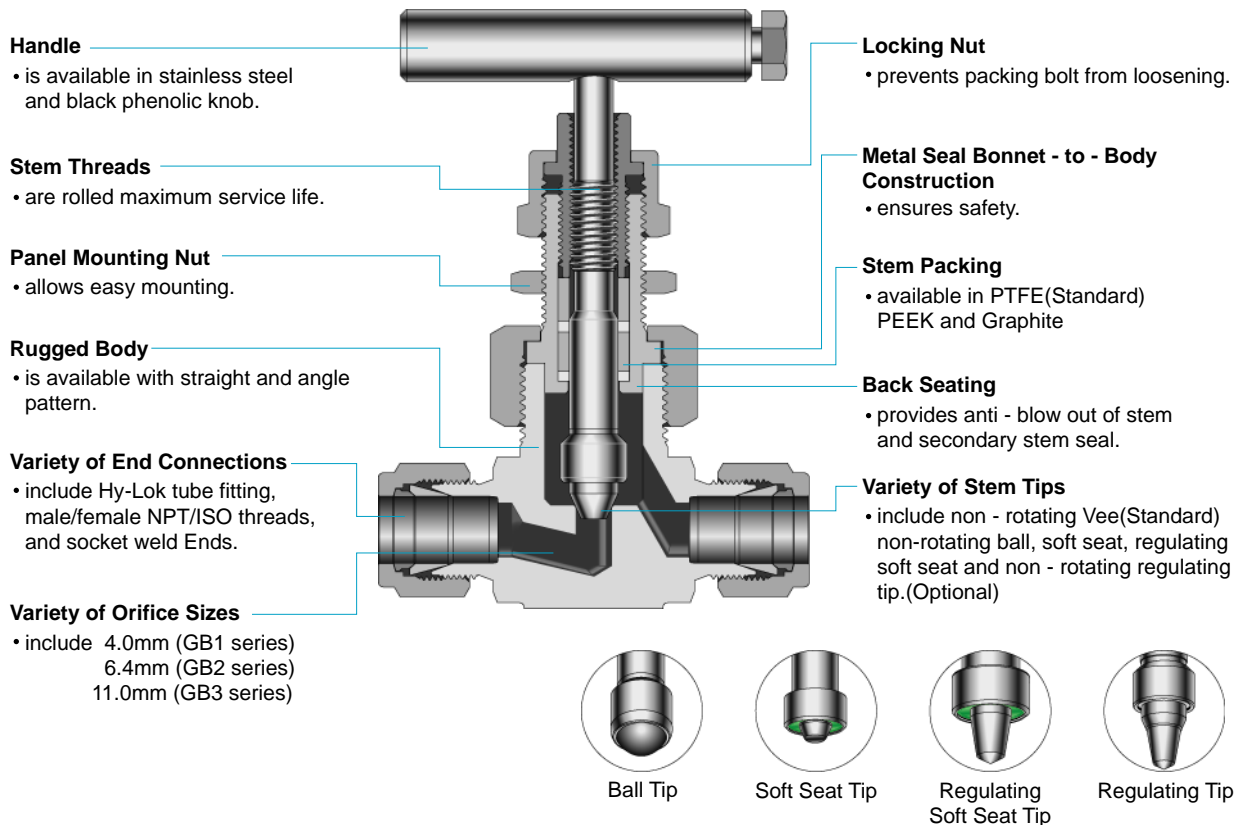

## Features

- Pressure rating** up to 6,000 psig (413bar) @ 100°F (38°C)
- Temperature rating** from -65°F to 450°F (-54°C to 232°C) with standard PTFE packing and up to 1,200°F (648°C) with optional Graphite packing
- Body materials** available in 316 stainless steel, carbon steel, and alloy 400
- 100% factory tested.**

**HY-LOK CORPORATION**

© 1997, 1998, 2000, 2002, 2003, 2006, 2014, 2019 HY-LOK CORPORATION All rights reserved



# Union Bonnet Valves

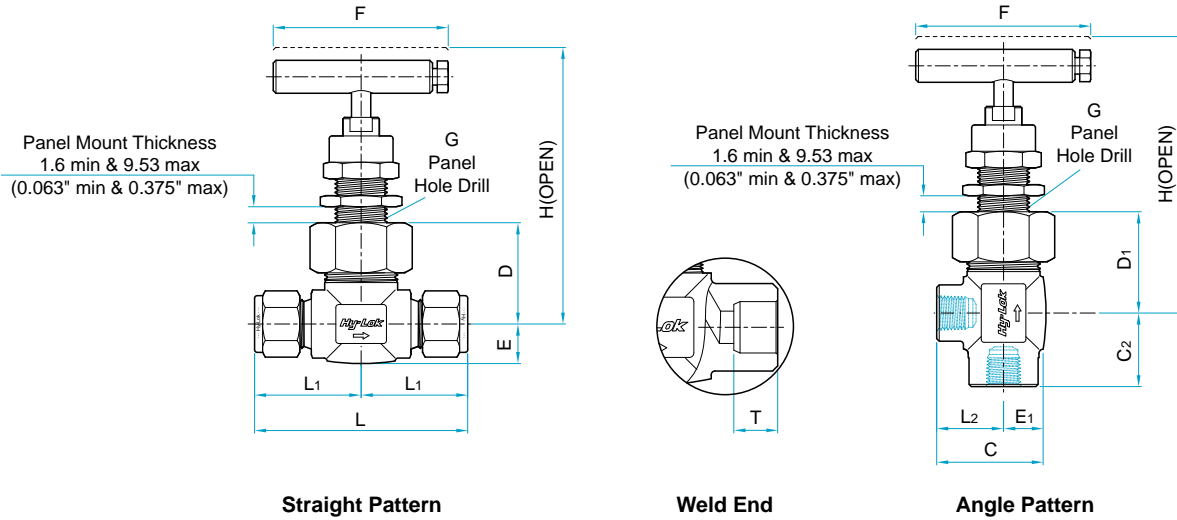

**Straight Pattern**

**Weld End**

**Angle Pattern**

## Table of Dimensions

Basic Part No.	Orifice Hole	Cv	End Connection		Dimensions														
			Inlet	Outlet	L	L <sub>1</sub>	L <sub>2</sub>	C	C <sub>2</sub>	D	D <sub>1</sub>	E	E <sub>1</sub>	F	G	H Straight	H Angle	T	
GB1	4.0 (0.16)	0.35	1/8" Female NPT		50.8 (2.00)	25.4 (1.00)	23.0 (0.91)	32.6 (1.28)	25.4 (1.00)	27.8 (1.09)	32.6 (1.28)	11.5 (0.45)	11.5 (0.45)	45 (1.77)	15.1 (0.59)	77.8 (3.06)	82.6 (3.25)	-	
			1/4" Female NPT		52.4 (2.06)	26.2 (1.03)													
			1/4" Male NPT		50.8 (2.00)	25.4 (1.00)	25.4 (1.00)	35.0 (1.38)											
			1/4" Male NPT   1/4" Female NPT		52.4 (2.06)	26.2 (1.03)	23.0 (0.91)	32.6 (1.28)											
			6mm Hy-Lok		61.9 (2.44)	31.0 (1.22)	29.4 (1.16)	38.9 (1.53)	33.7 (1.33)										
			1/4" Hy-Lok																
			1/4" Tube Weld		46.0 (1.81)	23.0 (0.91)	22.3 (0.88)	31.8 (1.25)	26.2 (1.03)										
			8mm Hy-Lok		61.9 (2.44)	31.0 (1.22)	29.4 (1.16)	38.9 (1.53)	33.7 (1.33)										
GB2	6.4 (0.25)	0.86	1/4" Female NPT		57.2 (2.25)	28.6 (1.13)	25.4 (1.00)	39.6 (1.56)	28.6 (1.13)	34.0 (1.34)	34.0 (1.34)	14.2 (0.56)	14.2 (0.56)	64 (2.52)	19.9 (0.78)	93.7 (3.69)	96.9 (3.81)	-	
			3/8" Female NPT																
			10mm Hy-Lok		73.0 (2.87)	36.5 (1.44)	33.7 (1.33)	47.9 (1.89)	37.6 (1.48)										
			3/8" Hy-Lok				33.5 (1.32)	47.7 (1.88)	37.5 (1.48)										
			12mm Hy-Lok		77.8 (3.06)	38.9 (1.53)	36.2 (1.43)	50.4 (1.98)	40.2 (1.58)										
			1/2" Hy-Lok				36.0 (1.42)	50.2 (1.98)	40.0 (1.57)										
			1/4" Pipe Weld						28.6 (1.13)										
			3/8" Tube Weld		57.2 (2.25)	28.6 (1.13)	25.4 (1.00)	39.6 (1.56)	25.4 (1.00)										
			1/2" Tube Weld																
GB3	11.0 (0.43)	2.2	1/2" Female NPT		79.4 (3.13)	39.7 (1.56)	33.3 (1.31)	50.8 (2.00)	39.7 (1.56)	46.1 (1.81)	47.0 (1.85)	15.9 (0.63)	17.5 (0.69)	76 (2.99)	26.2 (1.03)	121.5 (4.78)	122.4 (4.82)	-	
			3/4" Female NPT		82.6 (3.25)	41.3 (1.63)	41.3 (1.63)	61.8 (2.43)	38.0 (1.50)	48.4 (1.91)	49.5 (1.95)	19.9 (0.78)	20.5 (0.81)						
			1" Female NPT		92.1 (3.63)	46.0 (1.81)	-	-	-	54.0 (2.13)	-	25.4 (1.00)	-						-
			1/2" Male NPT   1/2" Female NPT		79.4 (3.13)	39.7 (1.56)	33.3 (1.31)	50.8 (2.00)	39.7 (1.56)	46.0 (1.81)	47.0 (1.85)	15.9 (0.63)	17.5 (0.69)						
			3/4" Male NPT   3/4" Female NPT		82.6 (3.25)	41.3 (1.63)	-	-	-	48.4 (1.91)	-	19.9 (0.78)	-						-
			1" Male NPT   1" Female NPT		92.1 (3.63)	46.0 (1.81)	-	-	-	54.0 (2.13)	-	25.4 (1.00)	-						-
			12mm Hy-Lok				-	-	-	-	-	-	-						-
			1/2" Hy-Lok				-	-	-	-	-	-	-						-
			3/4" Hy-Lok		100.0 (3.94)	50.0 (1.97)	47.0 (1.85)	61.1 (2.41)	50.0 (1.97)	46.0 (1.81)	47.0 (1.85)	17.5 (0.69)	17.5 (0.69)						19.0 (0.75)
			1" Hy-Lok				-	-	-	-	-	-	-						-
			1/2" Pipe Weld							47.6 (1.87)	-	17.5 (0.69)	-						-
			1/2" Tube Weld		79.4 (3.13)	39.7 (1.56)	33.3 (1.31)	50.8 (2.00)	39.7 (1.56)	46.0 (1.81)	47.6 (1.87)	15.9 (0.63)	19.0 (0.75)						
			3/4" Tube Weld					52.3 (2.06)	39.7 (1.56)	46.0 (1.81)	51.0 (2.00)								

All dimensions in millimeters (inch.) Dimensions shown with Hy-Lok nuts in finger-tight position, where applicable.

## Technical Data

### Materials of Construction

Description	Grade / ASTM Specification		
	Valve Body Materials		
	SS316	Carbon Steel	Alloy 400
Handle	Stainless Steel	Aluminum	Stainless Steel
Lock Nut	SS316 / A479 or A276	1020 / A108 JIS 4051 S20C	SS316 / A479 or A276
Packing Bolt	SS630 / A564		
Packing Gland	SS316 / A479 or A276	SS316 / A479 or A276	
Packing Support *	Reinforced PTFE		
Stem Packing *	PTFE		
Bonnet *	SS316 / A479	1020 / A108 JIS 4051 S20C	Alloy 400 / B164
Stem *	SS316 / A479 or A276		Alloy 400 / B164
Stem Tip *	Vee Tip	SS630 / A564	Alloy 400 / B164
	Ball Tip		
	Regulating		
	Soft Tip		
Body *	SS316 / A479 or A182	1020 / A108 JIS 4051 S20C	Alloy 400 / B164

**Note :** " \* " marked are wetted parts.  
 Nickel anti-seize lubricant for PTFE packed valves and fluorinated grease for PEEK and Graphite packed valves.

### Temperature vs Working Pressure

Temperature	Pressure (psig) @ Temperature Rating			
	ASME Group	2.2	NA	3.4
	Materials	SS316	Carbon Steel <sup>†</sup>	Alloy 400
	ASME Class	2500	NA	2500
-65 °F (-54 °C)	100 °F ( 38 °C)	6000	6000	5000
	200 °F ( 93 °C)	5160	5420	4400
	300 °F (148 °C)	4660	5320	4120
	350 °F (176 °C)	4470	5230	4050
	400 °F (204 °C)	4280	-	3980
	450 °F (232 °C)	4130	-	3970

<sup>†</sup> Rated at a low temperature of -20 °F (-29 °C)  
 To determine kPa, multiply psig by 6.89 and bar by 0.0689.  
 When valves with Hy-Lok fitting end connections are connected to tubing, the working pressure of tubing must be considered in the calculation of total system working pressure.

### Testing

- Each valve is tested with nitrogen @ 1000psig (69bar) to a max leak rate of 0.1 SCCM.
- Hydrostatic shell test is performed at 1.5 times the working pressure.
- Optional tests are available upon request.

### Temperature and Pressure Rating

Body Material	Stem Tip	Temperature Rating	Pressure Rating @ -65°F ~ 100°F (-54°C ~ 38°C)
316 Stainless Steel	NR Vee, NR Ball, Regulating	-65 °F ~ 450 °F (-54 °C ~ 232 °C)	6000 psig
	NR Soft Seat (PCTFE)	-65 °F ~ 200 °F (-54 °C ~ 93 °C)	
Carbon Steel	NR Vee, NR Ball, Regulating	-20 °F ~ 350 °F (-29 °C ~ 176 °C)	6000 psig
	NR Soft Seat (PCTFE)	-65 °F ~ 200 °F (-54 °C ~ 93 °C)	
Alloy 400 (monel)	NR Vee, NR Ball, Regulating	-65 °F ~ 450 °F (-54 °C ~ 232 °C)	5000 psig
	NR Soft Seat (PCTFE)	-65 °F ~ 200 °F (-54 °C ~ 93 °C)	

NR stands for non-rotating.  
 The above ratings are for a standard valve with PTFE packing.  
 For optional packing materials, refer to the table shown below.  
 Extreme temperature fluctuations may require packing adjustment.

### Packing and Body Materials vs Temperature and Pressure Rating

Packing Material	Body Material	Temperature	Pressure @ Temp Rating
PTFE (Standard)	316 Stainless Steel	-65 °F ~ 450 °F (-54 °C ~ 232 °C)	4130 psig
	Alloy 400 *		3970 psig
PEEK <sup>†</sup>	316 Stainless Steel	-65 °F ~ 600 °F (-54 °C ~ 315 °C)	3760 psig
	Alloy 400 *		-65 °F ~ 500 °F (-54 °C ~ 260 °C)
Graphite	316 Stainless Steel	-65 °F ~ 1200 °F (-54 °C ~ 648 °C)	1715 psig
	Carbon Steel	-20 °F ~ 350 °F (-29 °C ~ 176 °C)	52300 psig
	Alloy 400 *	-65 °F ~ 500 °F (-54 °C ~ 260 °C)	3960 psig

\* Not applicable over 500 °F (260 °C).  
<sup>†</sup> PEEK is not recommended for service with aromatic heat transfer fluids or concentrated sulfuric and nitric acids. Other limitations may apply.

### Sour Gas Service

- is provided to meet NACE Standard MR - 01 - 75.

### Steam and Severe Service

- To order, add-SB (Stellite Ball) to the valve ordering number.

### Handles

- Standards are black aluminum bar for carbon steel body and stainless steel bar for SS316 and Alloy 400 body.

## Flow Coefficient (Cv) vs Number of Handle Turns

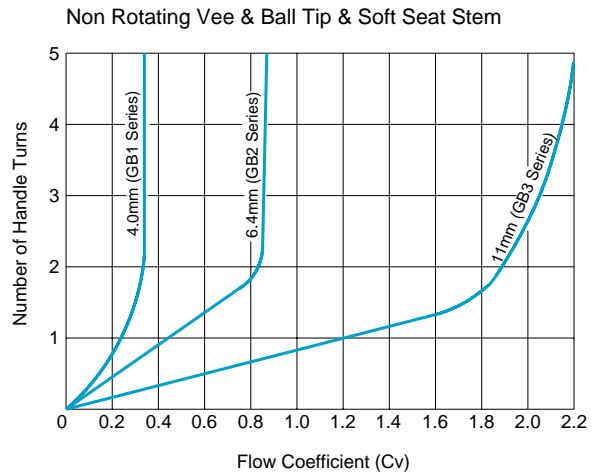
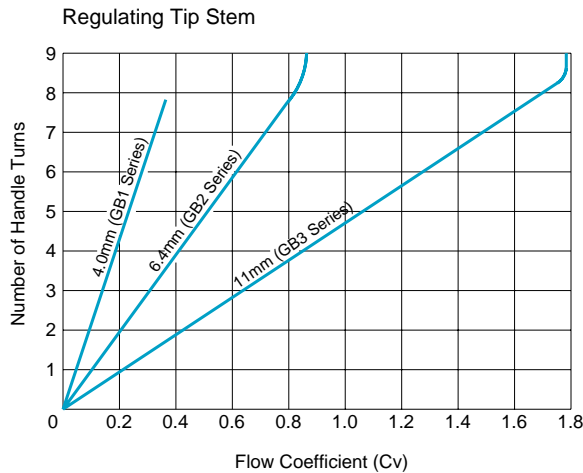

## Ordering Information

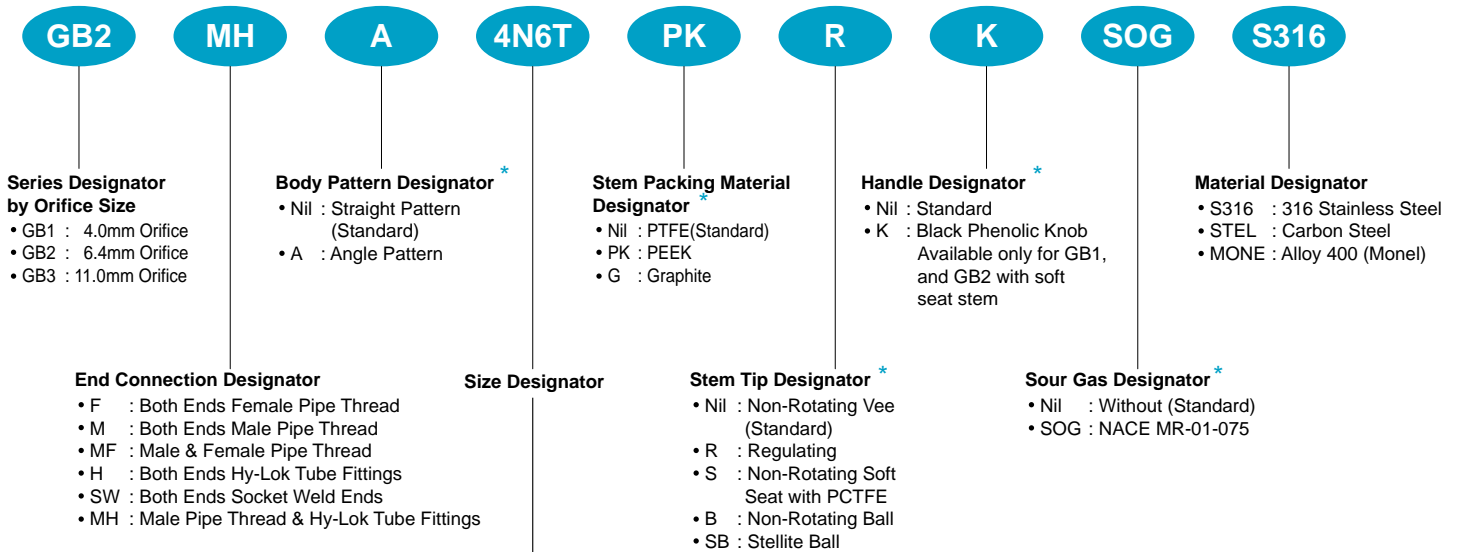

• NPT (ISO/BSP)

Thread (in.)	1/8	1/4	3/8	1/2	3/4	1
Designator	2N(R)	4N(R)	6N(R)	8N(R)	12N(R)	16N(R)

• Tube

Fractional Tube	O.D. (in.)	1/8	1/4	3/8	1/2	3/4	1
	Designator	2T	4T	6T	8T	12T	16T
Metric Tube	O.D. (mm)	3	6	10	12	20	25
	Designator	3M	6M	10M	12M	20M	25M

**Note** \* : No designator is required for standard, e.g. GB2MH-4N6T-S316.

## SAFETY in VALVE SELECTION

Proper installation, materials compatibility, operation and maintenance of these valves are the responsibility of the user. The total system design must be taken into consideration to ensure optimal performance and safety