

Hy-Lok SO Series

Swing Out Ball Valves

Catalog No. H-SOBV
Feb. 2004

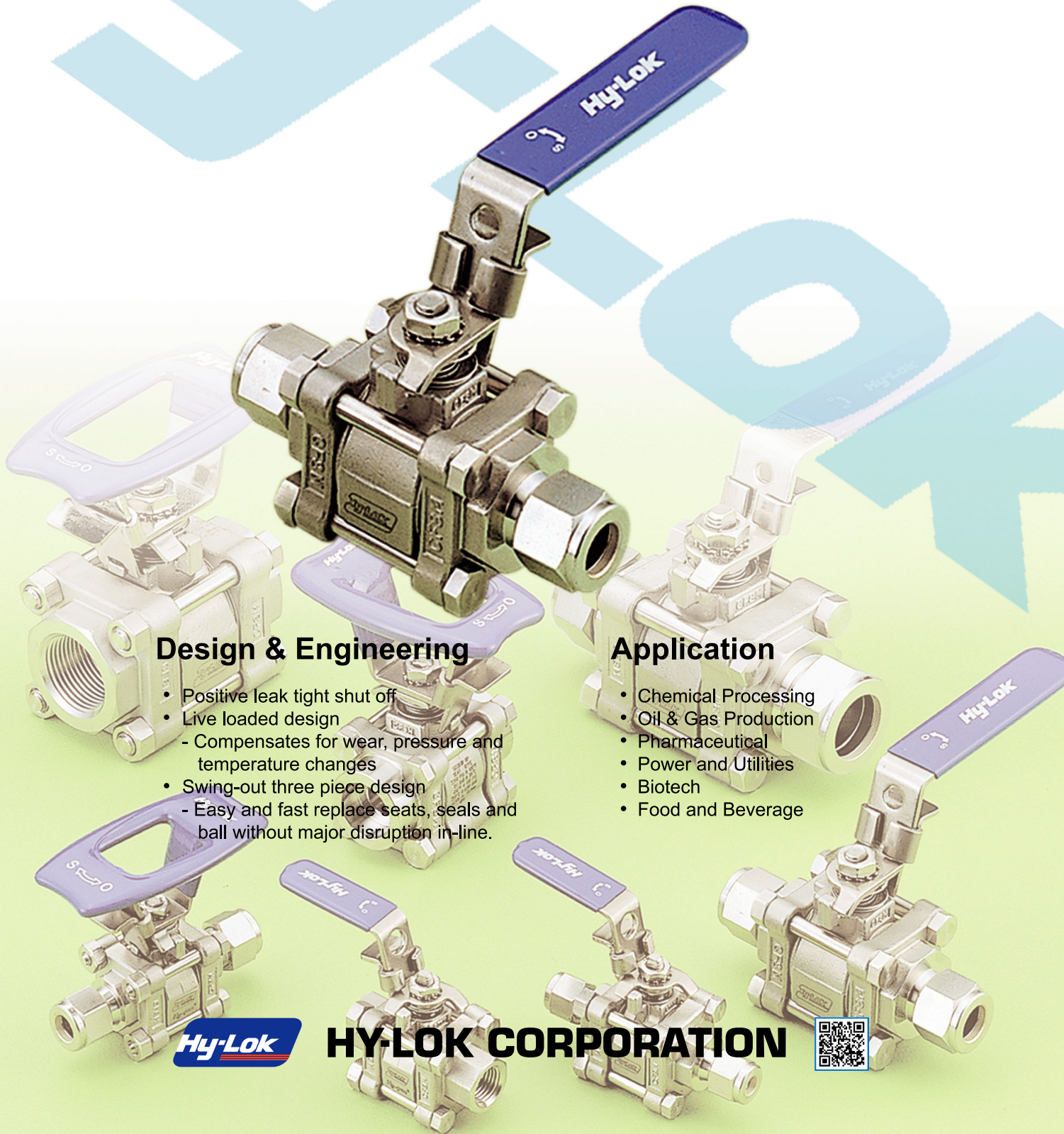

Design & Engineering

- Positive leak tight shut off
- Live loaded design
 - Compensates for wear, pressure and temperature changes
- Swing-out three piece design
 - Easy and fast replace seats, seals and ball without major disruption in-line.

Application

- Chemical Processing
- Oil & Gas Production
- Pharmaceutical
- Power and Utilities
- Biotech
- Food and Beverage

Hy-Lok

HY-LOK CORPORATION



Features and Benefits

- **Stem disc spring** compensates for temperature/ pressure changes
- **Ground spring** for Anti static
- **Chevron Stem Packing**
 - low operating torque
 - compensates for wear
- **Stem Bearing** is PEEK standard
- **Stem**
 - prevent stem blow-out
 - open/close indication
- **Precision machined ball** reduces torque & increases sealing



- **Lever Handle**
 - oval or extended handle option
 - low operation torque
- **Self-Locking device & pad lock**



- **Disc Spring & Seat**
 - compensates for wear and pressure / temperature changes
 - protects seats from pressure surge
 - allows leak-tight operation under various pressures
- **Support Ring** prevents seat bulging and wear
- **End packing with PTFE**
 - allows leak tight sealing between center
 - body and end connection flange
- **Center Body**
 - Swing-out design
 - available 3-Way (Switching)
- **High-strength 4-Bolt & Nut**

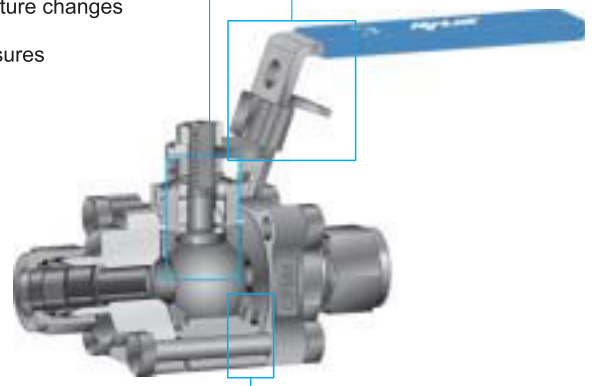
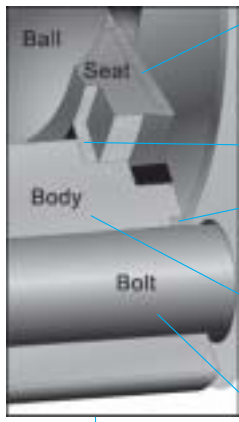

Specification

Pressure Rating up to 3000 psig(206bar) @ 100°F(38°C)
 Temperature Range from -20°F(-28°C) to 450°F(232°C)
 Size Range
 - Hy-Lok ends : 1/4" to 1" (6mm to 25mm)
 - Screwed ends : 1/8" to 1" (NPT, BSPT)
 - Butt-weld ends : 1/4" to 1" (Pipe)
 - Socket weld ends : 1/4" to 1" (Tube and Pipe)
 - ZCO O-Ring Face Seal ends : 1/4" to 1/2"
 - ZCR Metal Gasket Seal ends : 1/4" to 1/2"

Testing

- Each valve is tested with nitrogen @ 1000 psig (69 bar) to Max. leak rate of 0.1 SCCM.
- Hydrostatic shell test is performed at 1.5 times the working pressure as an option.
- Other tests are upon request.

Pressure and Temperature Rating

Seat Material	Valve Series	Pressure Rating at -20 °F to 100 °F (-28 °C to 38 °C) psig (bar)	Pressure Max. Temperature
Reinforced PTFE (Standard)	SO1B	2200 (151)	100 psig at 450 °F (7 bar at 232 °C)
	SO2B		
	SO3B		
PTFE	SO1B	1500 (103)	100 psig at 450 °F (7 bar at 232 °C)
	SO2B		
	SO3B		
UHMWPE (Polyethylene)	SO1B	3000 (206)	250 psig at 250 °F (17 bar at 121 °C)
	SO2B SO3B	2500 (172)	
Carbon PTFE	SO1B	2500 (172)	100 psig at 450 °F (7 bar at 232 °C)
	SO2B		
	SO3B		
PEEK	SO1B	3000 (206)	800 psig at 450 °F (55 bar at 232 °C)
	SO2B		
	SO3B		

Note

Pressure rating of switching valve is 1000psig(69bar) @ -20 °F to 100 °F (-28 °C to 38 °C)

Pressure & Temperature of Seat Material

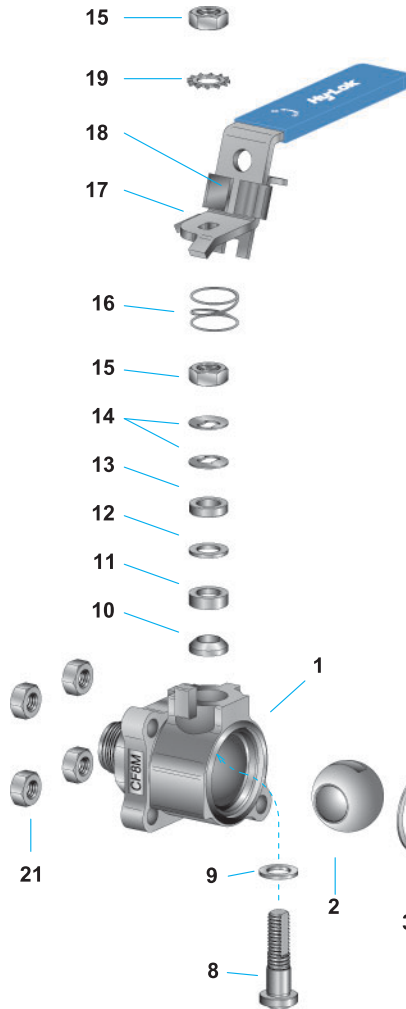
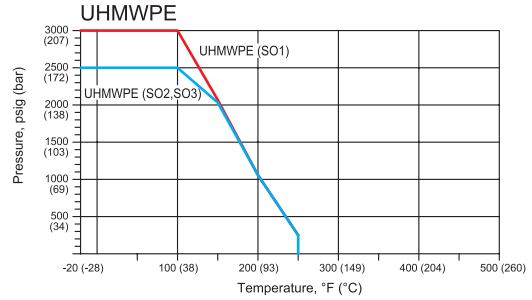
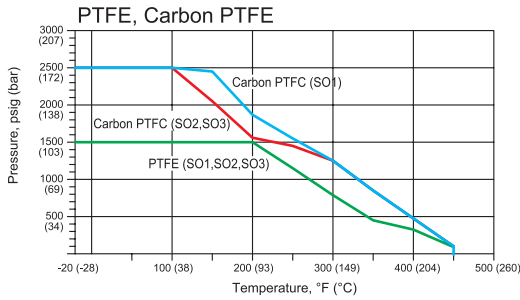
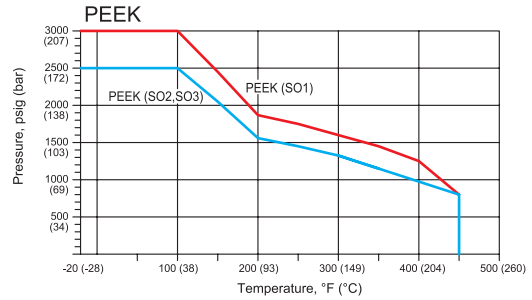
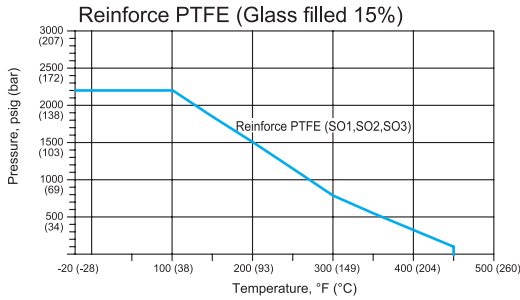

Materials of Construction

Description	Material / ASTM Specification
* 1 Body	CF8M / A351
* 2 Ball	Type 316 / A479
* 3 Support Ring (2)	Type 316 / A479
* 4 Seats (2)	Reinforced PTFE
* 5 Seat Spring (2)	17-7PH
* 6 Flange Seal (2)	PTFE
* 7 Flange (2)	CF8M / A351 or Type 316L / A479
* 8 Stem	Type 316 / A479
* 9 Stem Bearing	PEEK (Polyetheretherketone)
* 10 Lower Packing	Reinforced PTFE
* 11 Upper Packing	Reinforced PTFE
12 Packing Support	PEEK (Polyetheretherketone)
13 Gland	Type 316 / A479
14 Stem Spring (2)	Strain Hardened 316
15 Stem Nut (2)	Stainless Steel
16 Grounding Spring	Stainless Steel
17 Handle	Stainless Steel
18 Locking Device	Stainless Steel
19 Tooth Washer	Stainless Steel
20 Body Bolt (4)	Gr. B8M / A193
21 Body Nut (4)	Gr. 8M / A194

In case welding type, End connection is made of A479 TYPE 316L
 "*" marked are wetted parts.

Dimensions 2-Way (Shut-off)

Hy-Lok Tube End Connections

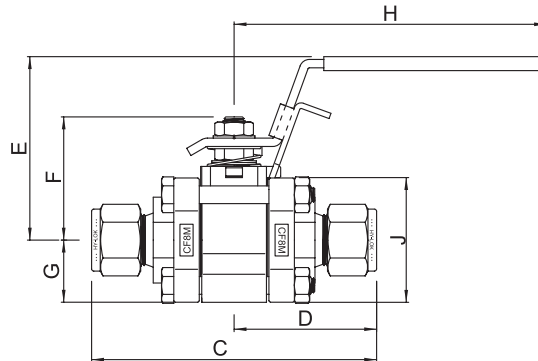

Basic Order No.	End Connection Size	Orifice		Cv	Dimensions (mm)						
		in.	mm		C	D	E	F	G	H	J
Fractional											
SO1BH- 4T	1/4"	0.188	4.8	1.2	80.8	40.40	47.7	31.8	16.75	57.2	33.0
SO1BH- 6T	3/8"	0.281	7.1	3.8							
SO2BH- 8T	1/2"	0.411	10.4	7.5	103.8	51.90	64.8	44.2	22.25	111.0	44.5
SO2BH-12T	3/4"	0.516	13.1	13.6							
SO3BH-16T	1"	0.875	22.2	40.0	136.7	68.35	79.0	61.9	31.00	149.4	62.0
Metric											
SO1BH- 6M	6mm	0.188	4.8	1.2	80.8	40.40	47.7	31.8	16.75	57.2	33.0
SO1BH- 8M	8mm	0.250	6.4	2.5							
SO1BH-10M	10mm	0.281	7.1	3.8							
SO2BH-12M	12mm	0.411	10.4	7.5	103.8	51.90	64.8	44.2	22.25	111.0	44.5
SO3BH-25M	25mm	0.875	22.2	40.0	136.7	68.35	79.0	61.9	31.00	149.4	62.0

Female Pipe Thread End Connections

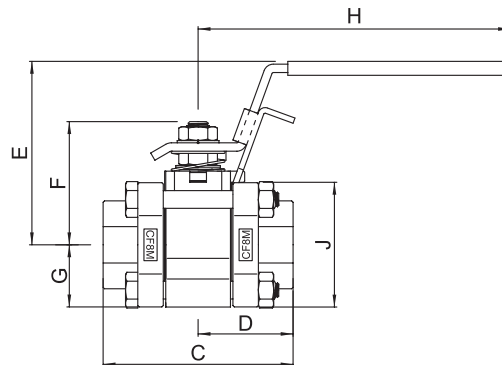

Basic Order No.	End Connection Size	Orifice		Cv	Dimensions (mm)						
		in.	mm		C	D	E	F	G	H	J
Female NPT (ASME B1.20.1)											
SO1BF- 2N	1/8" NPT	0.281	7.1	3.8	55.4	27.70	47.7	31.8	16.75	57.2	33.0
SO1BF- 4N	1/4" NPT			12.0							
SO2BF- 6N	3/8" NPT	0.516	13.1	12.0	68.9	34.45	64.8	44.2	22.25	111.0	44.5
SO2BF- 8N	1/2" NPT			31.0							
SO3BF-12N	3/4" NPT	0.875	22.2	31.0	92.0	46.00	79.0	61.9	31.00	149.4	62.0
SO3BF-16N	1" NPT			38.0							
Female ISO Tapered											
SO1BF- 4R	1/4" ISO Tapered	0.281	7.1	3.8	55.4	27.70	47.7	31.8	16.75	57.2	33.0
SO2BF- 8R	1/2" ISO Tapered	0.516	13.1	12.0	68.9	34.45	64.8	44.2	22.25	111.0	44.5
SO3BF-12R	3/4" ISO Tapered	0.875	22.2	31.0	92.0	46.00	79.0	61.9	31.00	149.4	62.0
SO3BF-16R	1" ISO Tapered			38.0							

Pipe & Tube Socket Weld End Connections

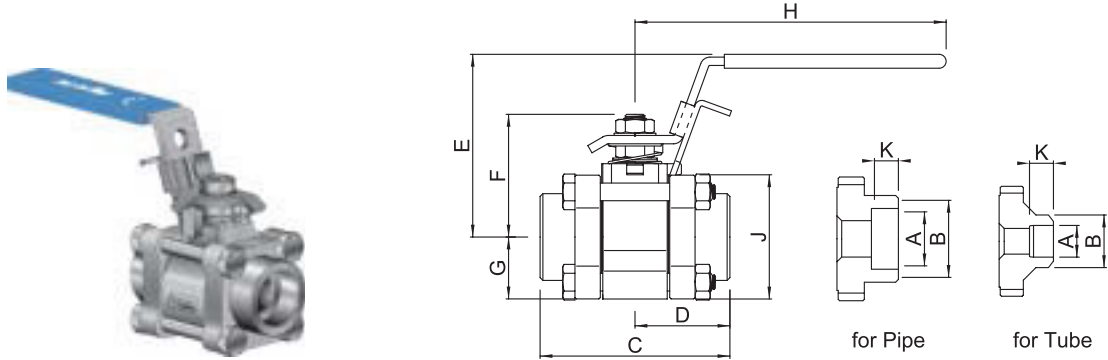

Tube Socket Weld

Basic Order No.	End Connection Size	Orifice		Cv	Dimensions (mm)									
		in.	mm		A	B	C	D	E	F	G	H	J	K
Tube Socket Weld														
SO1BSW- 4T	1/4"	0.188	4.8	1.2	6.50	13.70	55.4	27.70	47.7	31.8	16.75	57.2	33.0	7.1
SO1BSW- 6T	3/8"	0.281	7.1	3.8	9.70	17.10	55.4	27.70	47.7	31.8	16.75	57.2	33.0	7.9
SO2BSW- 8T	1/2"	0.411	10.4	7.5	12.90	21.30	68.9	34.45	64.8	44.2	22.25	111.0	44.5	9.7
SO2BSW-12T	3/4"	0.516	13.1	13.6	19.20	26.70	68.9	34.45	64.8	44.2	22.25	111.0	44.5	11.2
SO3BSW-16T	1"	0.875	22.2	40.0	25.65	33.40	92.0	46.00	79.0	61.9	31.00	149.4	62.0	16.0
Pipe Socket Weld														
SO2BSW- 8P	1/2"	0.516	13.1	15.0	21.80	31.20	68.9	34.45	64.8	44.2	22.25	111.0	44.5	9.7
SO3BSW-12P	3/4"	0.875	22.2	36.0	27.20	42.16	92.0	46.00	79.0	61.9	31.00	149.4	62.0	12.7
SO3BSW-16P	1"			42.0	33.90	45.30								

Pipe Butt Weld End Connections

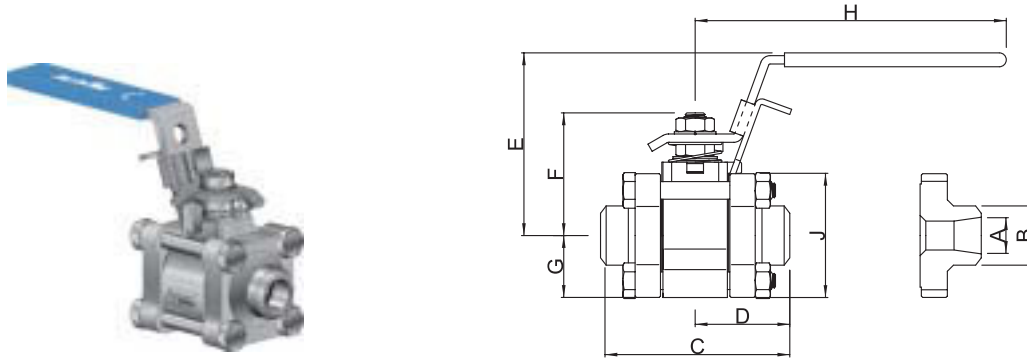

Basic Order No.	End Connection Size	Orifice		Cv	Dimensions (mm)									
		in.	mm		A	B	C	D	E	F	G	H	J	
Schedule 10														
SO1BBW- 4P-S10	1/4"	0.188	4.8	1.2	10.40	13.70	52.4	26.20	47.7	31.8	16.75	57.2	33.0	
SO2BBW- 8P-S10	1/2"	0.516	13.1	15.0	17.10	21.30	68.9	34.45	64.8	44.2	22.25	111.0	44.5	
SO3BBW-12P-S10	3/4"	0.875	22.2	36.0	22.45	26.67	92.0	46.00	79.0	61.9	31.00	149.4	62.0	
SO3BBW-16P-S10	1"			40.0	27.90	33.40	88.9	44.45						
Schedule 40														
SO1BBW- 4P-S40	1/4"	0.188	4.8	1.2	9.20	13.70	52.4	26.20	47.7	31.8	16.75	57.2	33.0	
SO2BBW- 8P-S40	1/2"	0.516	13.1	15.0	15.80	21.30	68.9	34.45	64.8	44.2	22.25	111.0	44.5	
SO3BBW-12P-S40	3/4"	0.875	22.2	36.0	20.93	26.67	92.0	46.00	79.0	61.9	31.00	149.4	62.0	
SO3BBW-16P-S40	1"			40.0	26.60	33.40	88.9	44.45						
Schedule 80														
SO1BBW- 4P-S80	1/4"	0.188	4.8	1.2	7.70	13.70	52.4	26.20	47.7	31.8	16.75	57.2	33.0	
SO1BBW- 6P-S80	3/8"	0.281	7.1	3.8	10.70	17.10	52.4	26.20	47.7	31.8	16.75	57.2	33.0	
SO2BBW- 8P-S80	1/2"	0.411	10.4	7.5	13.90	21.30	68.9	34.45	64.8	44.2	22.25	111.0	44.5	
SO2BBW-12P-S80	3/4"	0.516	13.1	13.6	18.80	26.70	68.9	34.45	64.8	44.2	22.25	111.0	44.5	
SO3BBW-16P-S80	1"	0.875	22.2	40.0	23.90	33.40	88.9	44.45	79.0	61.9	31.00	149.4	62.0	

Zero Clearance Face Seal End Connections

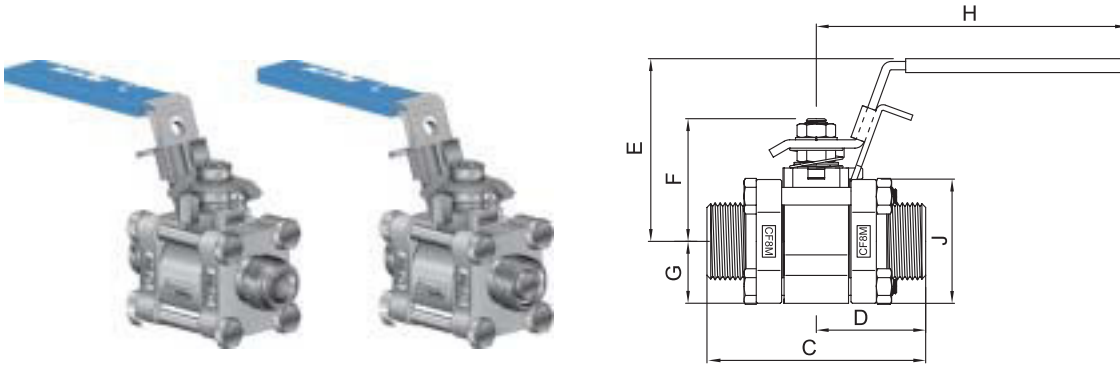

Basic Order No.	End Connection Size	Orifice		Cv	Dimensions (mm)						
		in.	mm		C	D	E	F	G	H	J
O-Ring Face Seal											
SO1BZCO-4	1/4" ZCO	0.188	4.8	1.2	66.6	33.3	47.7	31.8	16.75	57.15	33.0
SO2BZCO-8	1/2" ZCO	0.411	10.4	7.5	82.8	41.4	64.8	44.2	22.25	111.00	44.5
Metal Gasket Face Seal											
SO1BZCR-4	1/4" ZCR	0.188	4.8	1.2	63.6	31.8	47.7	31.8	16.75	57.15	33.0
SO2BZCR-8	1/2" ZCR	0.406	10.3	7.5	92.0	46.0	64.8	44.2	22.25	111.00	44.5

3-Way (Switching)

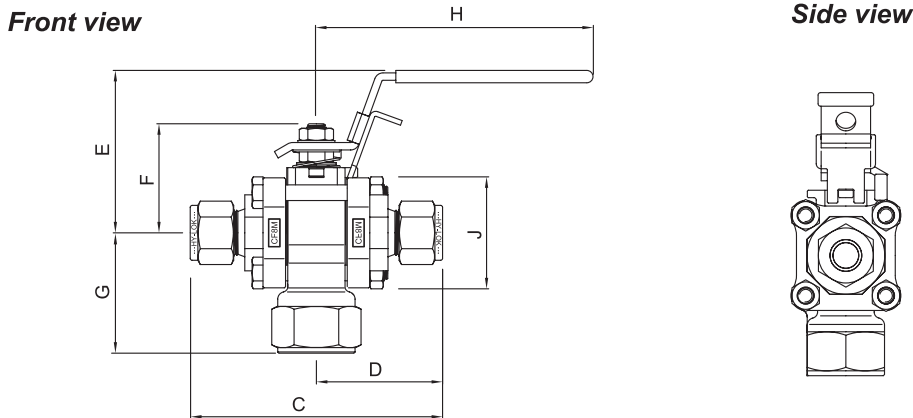

Basic Order No.	End Connection Size	Orifice		Dimensions (mm)							
		in.	mm	C	D	E	F	G	H	J	
Hy-Lok Tube Connections											
SO1B3H-4T	1/4"	0.188	4.8	80.8	40.40	47.7	31.8	43.6	57.2	33.0	
SO1B3H-6T	3/8"	0.281	7.1					44.5			
SO2B3H-8T	1/2"	0.411	10.4	103.8	51.90	64.8	44.2	59.0	111.0	44.5	
SO2B3H-12T	3/4"	0.516	13.1								
SO3B3H-16T	1"	0.812	20.6	136.7	68.35	79.0	61.9	74.9	149.4	62.0	
Female NPT (ASME B1.20.1)											
SO1B3F- 4N	1/4" NPT	0.281	7.1	55.4	27.70	47.7	31.8	36.5	57.2	33.0	
SO2B3F- 8N	1/2" NPT	0.516	13.1	68.9	34.45	64.8	44.2	49.0	111.0	44.5	
SO3B3F-12N	3/4" NPT	0.812	20.6	92.0	46.00	79.0	61.9	62.5	149.4	62.0	
SO3B3F-16N	1" NPT										
Female ISO Tapered											
SO1B3F- 4R	1/4" ISO Tapered	0.281	7.1	55.4	27.70	47.7	31.8	36.5	57.2	33.0	
SO2B3F- 8R	1/2" ISO Tapered	0.516	13.1	68.9	34.45	64.8	44.2	49.0	111.0	44.5	
SO3B3F-12R	3/4" ISO Tapered	0.812	20.6	92.0	46.00	79.0	61.9	62.5	149.4	62.0	
SO3B3F-16R	1" ISO Tapered			114.3	57.15						

Option

Oval Handle

Oval handle as an option.
For the ordering number of the oval handle, refer to the ordering information (page 8)



Vent Option

2-way valve is available with both internal or external vent and down stream or upstream vent

- Ball design for internal & external vent



- Downstream & Upstream vent

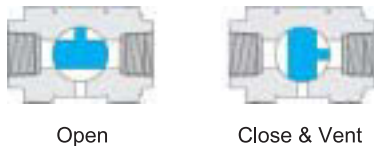

For the ordering number of downstream & upstream, refer to the ordering information (page 8)

Sour Gas Service

Valves are available in materials which comply with standard NACE MR-01-75 latest revision relating to metallic materials offering optimum resistance to sulfide stress cracking

Low Dead Space Inserts

2-Way is available with low dead space inserts. It prevents fluid entrapment around the ball and stem during operation. Low dead space insert is made of reinforced PTFE. Not suitable for steam, thermal and fire service.



Ordering Number
KIT- **** -LDSI

- * For a complete ordering number, insert the desired series designator as a suffix to the Low dead space insert kit basic ordering number. e.g : KIT-SO2B-LDSI

Mounting Bracket

panel mounting kit contains panel mounting bracket, body bolt for mounting, Round hex. socket head screw, cover plate.

- Horizontal and vertical mounting
- SO1B series - 3/16 in. (4.8mm)
- SO2B, SO3B series - 1/4 in. (6.4mm)
- Templets for panel drilling will be supplied.

Ordering Number
KIT- **** -PNM

- * For a complete ordering number, insert the desired series designator as a suffix to the panel mounting kit basic ordering number. e.g : KIT-SO2B-PNM



Actuator

So Series Ball Valves are available with Pneumatic Actuator and Electric Actuator. So Series Ball Valves can be supplied with Actuator and Mounting Bracket used to connect Valves to Actuators. For Actuator option, contact your local distributors.

Maintenance kits

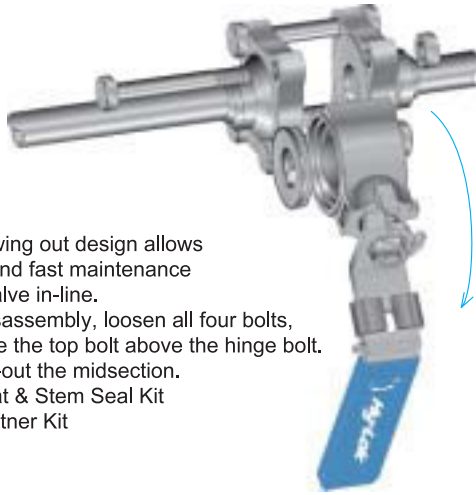

The swing out design allows easy and fast maintenance with valve in-line.
 For disassembly, loosen all four bolts, remove the top bolt above the hinge bolt. Swing-out the midsection.
 ■ Seat & Stem Seal Kit
 ■ Fastner Kit

Seat & Stem Seal Kits

Seat & stem seal kits contain components as below.

Basic Ordering No.	Seat Material	Component
KIT- **** -SEAL	RTFE	Seats, Seat springs, Support rings, End Packing, Stem bearings, Packings, Packing supports, Gland
	PTFE	
	RTFC	
	PEEK	
	UHMW	

* For a complete ordering number, insert the desired series designator as a suffix to the seal kit basic ordering number e.g : KIT-SO2B-SEAL / RTFC (Vee tip, Carbon filled seat)

Fastner Kits

Fastner kit contains valve component as below.

Basic Ordering No.	Bolt Material	Component
KIT- **** -FST	B8M	4-Hex. bolt & Nut, Stem nut

* For a complete ordering number, insert the desired series designator as a suffix to the fastner kit basic ordering number e.g : KIT-SO2B-FST



Ordering Information

SO2B	3	H	8T	PK	M	O	DV	SOG	S316																																															
<p>Valve Series Designator</p> <ul style="list-style-type: none"> • SO1B - 7.1mm Orifice • SO2B - 13.1mm Orifice • SO3B - 22.2mm Orifice 		<p>Body Pattern Designator</p> <ul style="list-style-type: none"> • Nil - Straight (Standard) • 3 - Switching 		<p>Panel Mounting Option*</p> <ul style="list-style-type: none"> • Nil - without • M - with 		<p>Handle Option*</p> <ul style="list-style-type: none"> • Nil - Lever (standard) • O - Oval with stop plate 		<p>Body Material Designator</p> <ul style="list-style-type: none"> • S316 - Stainless Steel A351 CF8M 																																																
<p>End Connection Designator</p> <ul style="list-style-type: none"> • H - Hy-Lok Tube Fittings • F - Female Thread • M - Male Thread • SW - Socket Weld • BW - Butt Weld • ZCO - O-Ring Face Seal Fittings • ZCR - Metal Gasket Face Seal Fittings 		<p>Seat Material Designator*</p> <ul style="list-style-type: none"> • Nil-Reinforce PTFE(Standard) • PK-PEEK • RC-Carbon PTFE • UH-UHMWPE 		<p>Size Designator</p>		<p>Vent Option*</p> <ul style="list-style-type: none"> • Nil - without (standard) • DV - Downstream vent • UV - Upstream vent 		<p>Sour Gas Option*</p> <ul style="list-style-type: none"> • Nil - without (standard) • SOG - NACE MR-01-75 																																																
<table border="1"> <thead> <tr> <th>Size</th> <th>Hy-Lok Tube Fitting & Tube Socket Weld</th> <th>NPT (ISO/BSP)</th> <th>Pipe Socket/Butt Weld</th> <th>ZCO O-Ring & ZCR Metal Gasket Face Seal</th> </tr> </thead> <tbody> <tr> <td>1/8</td> <td>3mm</td> <td>2T</td> <td>3M</td> <td>2N (R)</td> <td>2P</td> <td>-</td> </tr> <tr> <td>1/4</td> <td>6mm</td> <td>4T</td> <td>6M</td> <td>4N (R)</td> <td>4P</td> <td>4</td> </tr> <tr> <td>3/8</td> <td>10mm</td> <td>6T</td> <td>10M</td> <td>6N (R)</td> <td>6P</td> <td>-</td> </tr> <tr> <td>1/2</td> <td>12mm</td> <td>8T</td> <td>12M</td> <td>8N (R)</td> <td>8P</td> <td>8</td> </tr> <tr> <td>3/4</td> <td>20mm</td> <td>12T</td> <td>20M</td> <td>12N (R)</td> <td>12P</td> <td>-</td> </tr> <tr> <td>1</td> <td>25mm</td> <td>16T</td> <td>25M</td> <td>16N (R)</td> <td>16P</td> <td>-</td> </tr> </tbody> </table>										Size	Hy-Lok Tube Fitting & Tube Socket Weld	NPT (ISO/BSP)	Pipe Socket/Butt Weld	ZCO O-Ring & ZCR Metal Gasket Face Seal	1/8	3mm	2T	3M	2N (R)	2P	-	1/4	6mm	4T	6M	4N (R)	4P	4	3/8	10mm	6T	10M	6N (R)	6P	-	1/2	12mm	8T	12M	8N (R)	8P	8	3/4	20mm	12T	20M	12N (R)	12P	-	1	25mm	16T	25M	16N (R)	16P	-
Size	Hy-Lok Tube Fitting & Tube Socket Weld	NPT (ISO/BSP)	Pipe Socket/Butt Weld	ZCO O-Ring & ZCR Metal Gasket Face Seal																																																				
1/8	3mm	2T	3M	2N (R)	2P	-																																																		
1/4	6mm	4T	6M	4N (R)	4P	4																																																		
3/8	10mm	6T	10M	6N (R)	6P	-																																																		
1/2	12mm	8T	12M	8N (R)	8P	8																																																		
3/4	20mm	12T	20M	12N (R)	12P	-																																																		
1	25mm	16T	25M	16N (R)	16P	-																																																		
<p>Note* : No designator is required for standard e.g. SO2B3H-8T - S316</p>																																																								

SAFETY in VALVE SELECTION

Proper installation, materials compatibility, operation and maintenance of these valves is the responsibility of the user. The total system design must be taken into consideration to ensure optimal performance and safety